

Manual

goSilver Plus v2

Content

01	Foreword	Seite 4
02	Operation	Seite 5
03	Selection menu	Seite 6
04	Setting options	Seite 6
05	Start of electrolysis	Seite 8
06	Status screen	Seite 9
07	Final screen	Seite 11
08	Production	Seite 12
09	Notes	Seite 16
10	Contact	Seite 16

01 Foreword

Thank you very much for choosing the goSilver Plus for your own production of colloidal silver.

The software together with the TRUEppm® technology - taking into account all the additional factors - fully automatically ensures a consistently high quality of production.

With the goSilver Plus, you can produce both colloidal silver with cold water & ionic silver under constant heat of about 95° C (In this case please read the safety note on page 16.)

02 Operation

The operation of the device is simple and intuitive. All desired settings can be made with the use of the multifunctional rotary knob.

After starting the electrolysis, the status of the production can be checked on the display. At the end of the electrolysis, the final screen shows a summary of the respective production.

Please familiarize yourself with the operation of the goSilver Plus before the first production. To do this, plug the power plug into a power outlet and connect USB cable with the device. The start screen appears on the display. Pressing selects or confirms a selection.

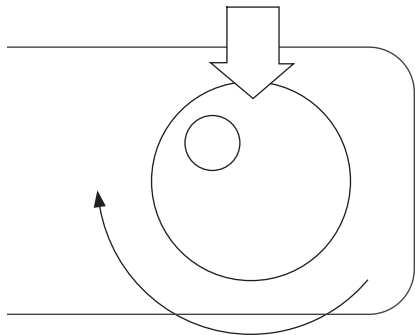

03 Selection menu

After the start screen, the selection menu appears automatically. The arrow (cursor) is in the line „go!“. If the adjusted values fit, you can start the electrolysis directly.

If you want to set the parameters (amount of water, ppm concentration, etc.) you can turn the rotary knob to reach the other lines and choose your desired settings. To do this, move the cursor to the line that you want to change.

Water	cold
> Liters	0,5
mg/L	10
	go!

By pressing, the value can be edited - the value now flashes. By turning, the desired value can now be set and fixed by pressing it again. Further details under „04 settings options“.

All set values are being saved also when you shut off and restart the device.

04 Setting options

04.1 Liters

You can set amounts of water between 0.1 and 40 liters.

04.2 ppm* oder mg/L

You can choose between the unit ppm* or milligrams per liter (mg / L). Concentrations of **1 to 99,9 mg/L** or **5 to 500 ppm*** are possible. *In case of production with cold water, the concentration is limited to 20mg / L or 100ppm*, as the production time would be disproportionately long at higher concentrations.*

04.3 Water — warm oder cold

You can configure the device for production with cold water (room temperature or initially heated) or with hot water (approx. 95 °C).

The production with hot water is only possible with an accessory, further information can be found on page 16.

▲ More settings

Moving the cursor beyond the top of the display will take you to more settings.

Beep	1s
Language	german
> Unit	mg/L

04.4 Unit — ppm or mg / L

The concentration is set either in ppm* (as previously used) or in milligrams per liter (mg / L). See explanation at *10 More information* on page 18.

04.5 Language — German / English

You can change the operating language of

your goSilver Plus to German or English. The change comes into effect after the setting has been fixed.

04.6 Beep - 0, 1, 3, 6, 9 s

An acoustic signal sounds at the end of the manufacturing process. The duration of the tone can be set. Either off (0s) or 1, 3, 6, 9 seconds.

You do not have to return to the settings screen until you want to change the setting. All settings are saved permanently (even after switching off the device).

05 Start of electrolysis

Press ,go!' To start production with all set parameters, if distilled water is used and the software's water test is positive. For safety reasons the device will not start if you use tap water, heavily contaminated water or even colloidal silver, even if only in small quantities.

Please use
distilled water!

If the water test is positive, the device displays the message: „Water ok.“

If you want to make Colloidal silver with hot water (95 ° C), please read note on page 16!

06 Status screen

During the manufacturing process, the most important settings are displayed and additional information can be used to monitor the progress of the electrolysis.

06.1 Liters

The selected amount of water

06.2 ppm* or mg/L

Depending on the setting, either the already generated ppm * or the already generated mg / L are displayed.

06.3 Remaining time

The expected remaining time is displayed dynamically in hours and minutes. At the start, the software calculates the remaining time with

an assumed average current. By measuring the current in seconds, the indication of the remaining time becomes more and more accurate, but still remains an estimate, since the future current is not foreseeable.

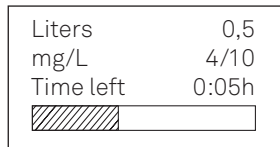

If the calculated remaining time is longer than the possible maximum display possibility of 99: 59h, this value remains until the calculated remaining time has become smaller than the maximum display possibility.

06.4 Progress bar

The progress of the electrolysis is also indicated visually as a progress bar.

06.5 Expert Mode

By turning the rotary knob during production, you can switch to the expert mode. The remaining time display is replaced by a voltage and current indication in the display.

Those who are interested in technology can observe the interplay of voltage and current for the generation of the obligatory constant current.

06.6 Polarity reversal

The goSilver Plus changes the polarity of the electrodes approximately every 15 seconds. This prevents excessive formation of electrode sludge and possibly short circuits between the electrodes.

The electrodes do not need to be cleaned during manufacture. The flawless function of the polarity change can be recognized by a flashing dot in the remaining time display. The flashing dots

also signal the current flow. If the electrodes are not yet in distilled water, there is no current and the dots do not flash.



07 Final screen

When the electrolysis is finished, the goSilver Plus switches to standby mode. The final screen summarizes the amount of water and concentration produced.

Liters	0,5
mg/L	10/10
 ready!	

Note: The goSilver Plus switches to standby mode at the end of production and remains ready for further production. Accordingly, the goSilver Plus does not turn itself off. If desired, disconnect the device from the USB power adapter.

Manual termination of production

The manufacture can be terminated manually at any time by holding down the rotary knob for more than 2 seconds. All information will be frozen on the status screen. The concentration produced up to this point is also displayed. In addition, the note (stopped) appears on Liters 0,25 the screen.

Liters	0,5
mg/L	4/10
stopped	0:05h
	

08 Production

08.1

Pour distilled water, preferably ‚Ampuwa for Dishwashing‘ into a glass jar. Under no circumstances should you use plain tap water, this can form harmful chemical compounds with the silver.

08.2

Connect the 5 volt USB power adapter (if not already done) to the goSilver Plus using the cable.

08.3

Screw the silver electrodes into the supplied adapters. Insert the silver electrodes with the adapter first into the bottom of the device. With the goSilver Plus you can connect a pair of electrodes, with the goSilver Plus 8 you can connect one, two, three or four pairs.

The device recognizes the number of electrodes and includes this in the calculation of the production time. The more pairs, the faster the production process. Please always use the opposite jack in pairs.

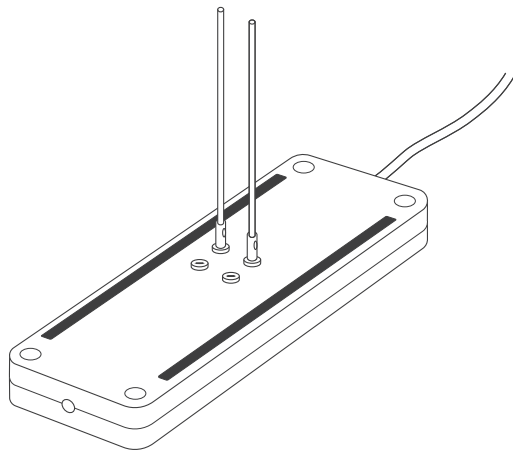

Note: Please do not touch the silver electrodes with your bare fingers. Any fat residues could affect the production. The silver electrodes only shine initially after they come out of production. After the first use, they change to a matt gray color, which is completely normal.

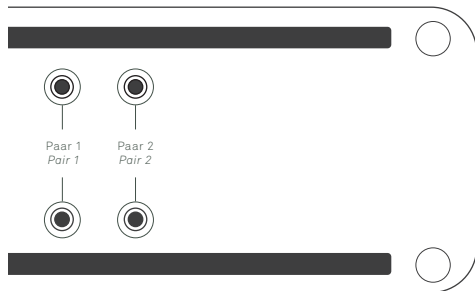

08.4

Then place the device with the electrodes first on a glass jar. The electrodes should dip into the water, but not the adapters.

The distance between the surface of the water and the adapters should be about 5mm, in a production with permanent 90 ° C about 10mm.

If the electrodes or adapters are too deep into the water, pour some water away. The calculation of the production time is only minimally affected.

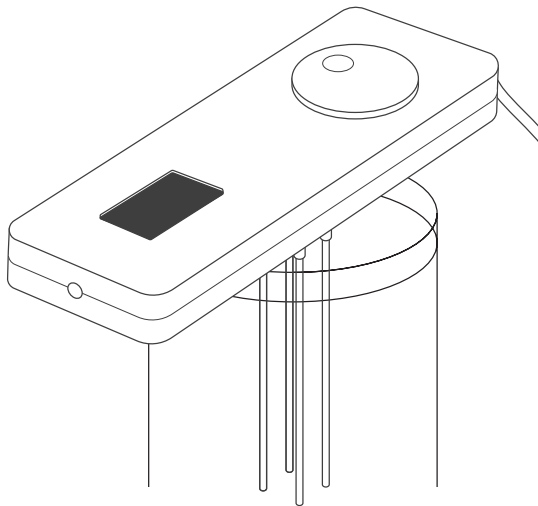

08.5

As a precaution, fix the supply cable with tape on the table and make sure that the device can not fall into the vessel.

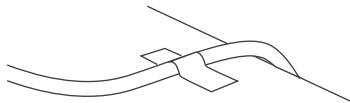

08.6

After you have previously made your desired settings on the goSilver Plus, start the electrolysis process. After a successful water test, goSilver Plus starts and the display changes to the status display.

08.7

When the desired concentration is reached, the device automatically switches to standby mode.

Depending on the setting, a beep sounds and the final screen is shown in the display.

08.8

After use, wipe the silver electrodes while still wet with a dry cloth.

If you have produced Ionian Silver with cold water, please protect the suspension from direct sunlight and seal it airtight in a suitable (brown or blue glass) container. Colloidal silver produced under permanent heat is less sensitive to external influences.

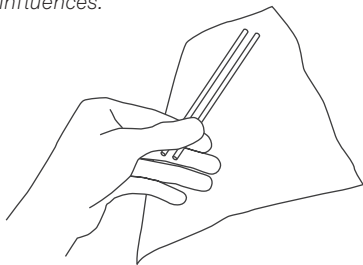



09.1 Do not use tap water

Under no circumstances should you use plain tap water. This can form harmful chemical compounds with the silver.

09.2 Overdose

The „ppm“ dosage recommendations in most publications in Germany do not reflect the actual silver content in the suspension. Please never set the same number in milligrams per liter (mg / L) for any of these previous recommendations. That would be 5 times the recommended dose.

Further information can be found in the next chapter on page 17.

09.3 Do not expose the device to hot steam

Please do not place the device on boiling water, it is not designed for this. For production with hot water or wide vessels, please use the external electrode holder available in our shop (gosilver.de/shop).

10 Additional Information

10.1 Explanation ppm *

The unit ppm (parts per million) of two identical substances is historically determined in the production of colloidal silver (KS), but it is incorrect because water and silver are not two identical substances. For the sake of simplicity, it is also assumed that 1 liter of water has a mass of 1 kg.

It is approximately assumed that 1 ppm corresponds to ≈ 1 milligram per liter (mg / L).

Years of error in manual production with conventional devices and with the help of a chart have shown that the actual silver content in the suspension is only about 20% of the assumed concentration. All recommended concentrations in the publications regarding KS are subject to this error.

Since ppm has become irrevocably naturalized and in order to be able to continue to produce KS with the previous concentration recommendations, with the goSilver Plus v2 there is the possibility of the one that has been used up to now but is not applicable Select unit ppm *. Since the Concentration here is only about 20% the ppm unit for the goSilver Plus v2 is marked with a *. Also to make the difference to the actual ppm or mg / L clear.

The setting mg / L should preferably be selected, as this setting corresponds to the actual silver content in the suspension in milligrams per liter.

The goSilver Plus v2 software is programmed as follows:

$$1 \text{ ppm}^* = 0,2 \text{ mg/L}$$
$$1 \text{ mg/L} = 5 \text{ ppm}^*$$

Further information on this topic can be found on: www.gosilver.de/ppm

10.2 Manufacturing methods

1.)

Production with cold water (room temperature, setting: cold water). This type of production takes the longest, as the low conductivity of the (cold) water means that only a very small current can flow at the beginning. The software measures the current every second and calculates the production time. In this type of production, the laws of physics mean that the silver ions in the suspension repel each other and float in it. The suspension remains clear. It mainly contains silver ions and only a few colloids are formed. One speaks of „ionic colloidal silver“.

2.)

Production with initially heated water. (Setting: water cold) With this type of production, the water is initially heated. The electrolysis then takes place during the cooling process.

By heating the working current can be reached faster, the duration of the electrolysis is shorter than without prior heating. The suspension usually remains clear, but can also take on a light yellow color. As with manufacturing method 1, the silver ions predominate and few colloids are formed. One speaks of „ionic colloidal silver“.

3.)

Production with permanent heat. (Setting: hot water) With this type of production, the individual silver ions combine to form colloids during the electrolysis. The dispersion contains only a few silver ions and, depending on the concentration, takes on a light yellow to black color. One speaks of „colloidal silver“.

10.3 Concentrations

goSilver Plus v2 enables 1,360 combinations of water volume, number of electrode pairs, water temperature and concentration. It is not possible to test and guarantee all of these combinations.

Only the following and mostly required settings have been tested and guaranteed under the following conditions:

Beaker: 1 liter Boro 3.3, tall form

Electrodes: 1 pair of fine silver 99.99 hard-rolled 2.7 by 120mm

Water: Ampuwa for rinsing purposes

Water with room temperature approx. 22 ° C (Setting cold)

Water permanently hot approx. 95 ° (Setting hot)

2.5mg / L, 5mg / L, 10mg / L and 20mg / L (cold)
2.5mg / L, 5mg / L, 10mg / L and 20mg / L (hot)

These values correspond to the usual ppm * values of 12.5ppm *, 25ppm *, 50ppm * and 100ppm *

The results are verified by laboratory analysis by the chemistry department of the Ludwig Maximilians University of Munich (LMU) with the corresponding measurement tolerance of the ICP-OES measurement method.

More information on
gosilver.de/herstellungsarten

General information on colloidal silver (German):
vitalinstitut.net/kolloidales-silber

goSilver®

goSilver GmbH
Kirchberg 8a
86919 Utting am Ammersee
Germany

www.gosilver.de
mail@gosilver.de